

MOBEX F-60

(09.838)

Motor	(kW)	4,0	Filter surface	(m ²)	60
Voltage	(V)	400	No. of filter elements	(pc)	3
Rated frequency	(Hz)	50	Filter cleaning		Jet-Pulse
Fuse	(A)	16	Dust collection drawer	(liter)	100 – 150
max.airflow	(m ³ /h)	4.500	Dimensions (L × W × H) (mm)		2.030×1.040×2.030
max. neg. pressure	(Pa)	3.400	Weight	(kg)	ca. 350
Intake	(mm)	280	Comp. air requirement	(l/impuls)	ca. 19
Sound level	(dBA)	74	Comp. air connection	(bar)	4 – 6

* with 4 bar and valve opening time of 0.12sec

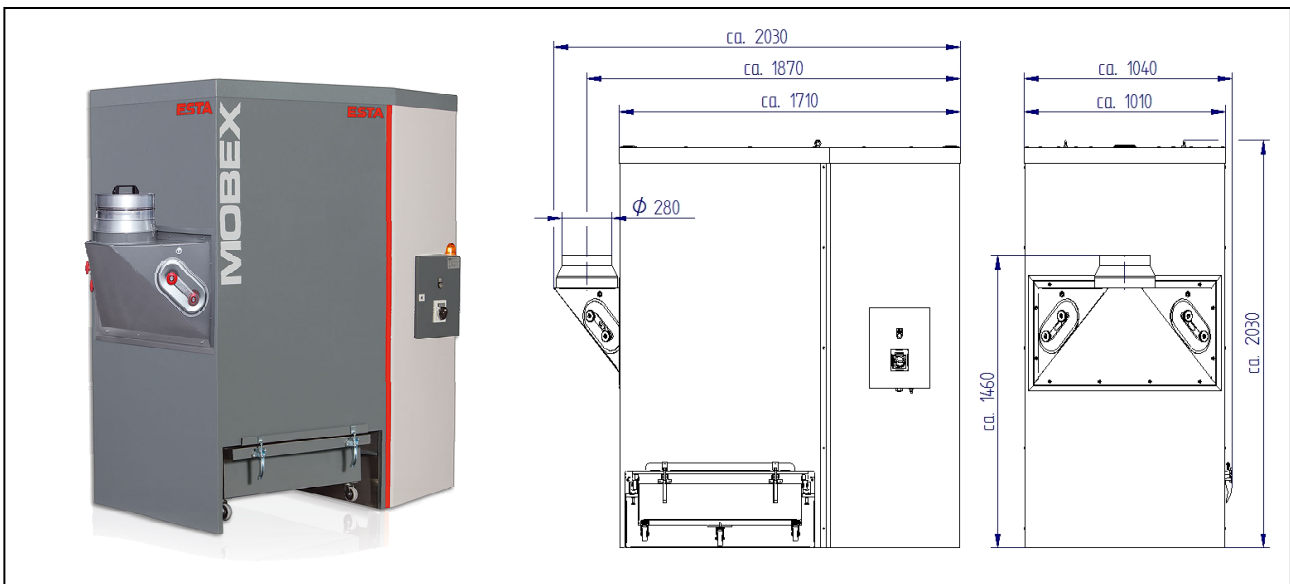

ESTA PLUS

Application range:

- Single and multiple extraction in industrial plants or smaller workshops
- Dry, pourable, non-flammable welding fumes

Your benefits at a glance:

- All-purpose for welding fumes
- Tight and powerful
- Convenient dust disposal
- Low operation noise
- Low operating costs
- Test certificates for special applications

Characteristics:

- Automatic jet pulse filter cleaning system
- Cleanable long life cartridge filters (dust classification M)
- Integrated impact separator
- Easy replaceable dust collection bins
- New housing structure of sandwich panel

Modification:

- Filter cartridges with advanced properties
- With pre-separator
- Mobile on wheels (H + 107 mm)
- With dry contact for external control
- Exhaust air socket
- Test certificates for special applications (W3)

State of the art: 09838-51-05 Subject to change without notice! For remaining questions please do not hesitate to contact us.