

DUROSOG-W/N

(80.24N)

| | | | | | |
|-----------------|------|---------|-----------------------|---------------------|-----------------|
| Voltage | (V) | 230 | Max. neg. pressure | (Pa) | 22.000 |
| Motor | (kW) | 3 x 1,0 | Max. airflow | (m ³ /h) | 360 |
| Current | (A) | 13 | Weight | (kg) | |
| Rated frequency | (Hz) | 50 | Intake | (mm) | 50 |
| Fuse | (A) | 16 | Dust collection bin | (Liter) | 70 |
| | | | Dimension (L x W x H) | (mm) | 660 x 630 x 950 |

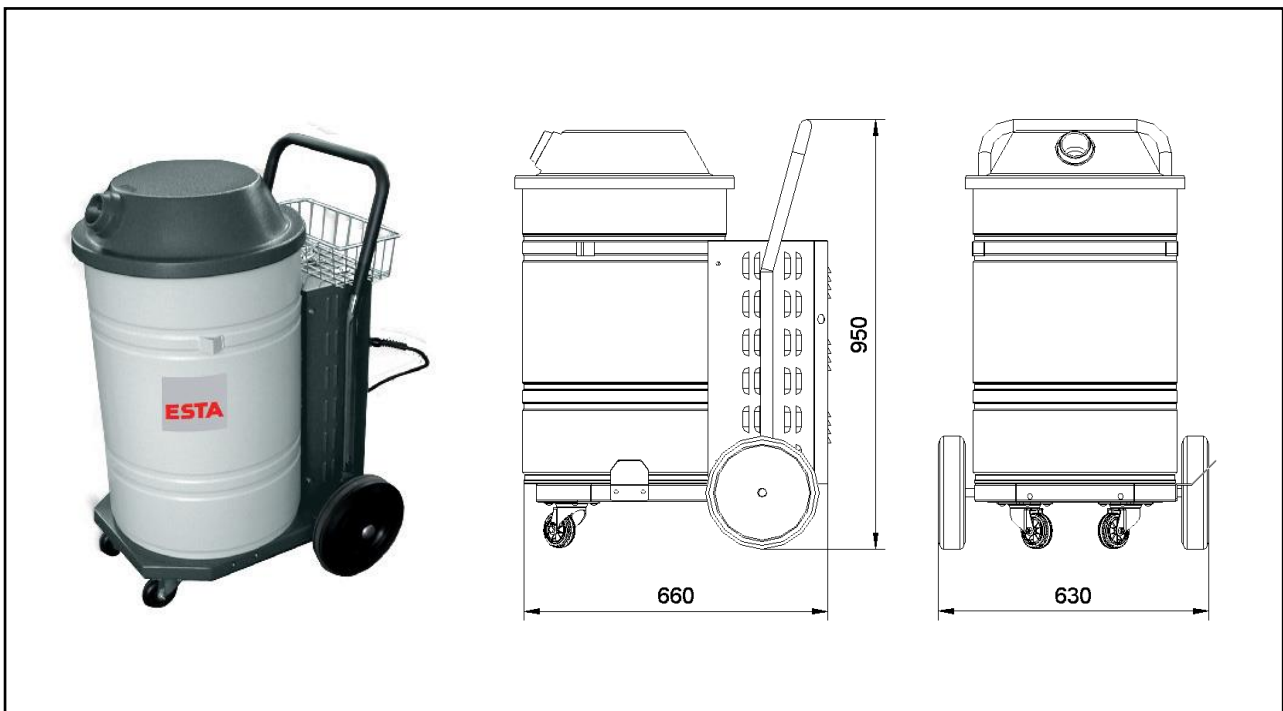

ESTA PLUS

Application range:

- For sticky substances and dust that tends to clump
- Removal of dusts that are hazardous to health and cancer-causing

Characteristics:

- Equipped with pre-separator
- paper filter bag
- cloth filter

Your benefits at a glance:

- With the use of special filtration technology this model is suitable for dry dust, sticky dust and dust that tends to clump
- Tight and easy-to-handle design

Modification:

- Special voltage
- Special painting
- Installation of a pre-separator possible

State of the art: 8024N-51-00 Subject to change without notice! For remaining questions please do not hesitate to contact us..